

70 AG series

x70x25mm



General Specifications

- Motor : 4 Poles brushless DC motor
- Frame & Impeller : Plastic(UL 94V-0)
- Storage temperature : -40° to +75°
- Operating temperature : -10° to +70°

Major Characteristic Parameters

| Model | *Bearing System | Rated Voltage | Operating Voltage Range | Rated Current | Rated Speed | Maximum Air Flow | Maximum Static Pressure | Sound Level | Weight | | |
|--------------|-----------------|---------------|-------------------------|---------------|-------------|---------------------|-------------------------|---------------------|---------------------|------|----|
| Part NO. | B / S / F | V | V | A | RPM | m ³ /min | CFM | mm-H ₂ O | In-H ₂ O | dBA | g |
| AGE07025_12L | B / S | 12 | 7.0~13.2 | 0.07 | 3000 | 0.85 | 30.0 | 3.9 | 0.15 | 27.0 | 74 |
| AGE07025_24L | B / S | 24 | 14.0~26.4 | 0.05 | 3000 | 0.85 | 30.0 | 3.9 | 0.15 | 27.0 | 74 |
| AGE07025_48L | B / S | 48 | 28.0~56.0 | 0.04 | 3000 | 0.85 | 30.0 | 3.9 | 0.15 | 27.0 | 74 |
| AGE07025_12M | B / S | 12 | 7.0~13.2 | 0.09 | 3600 | 1.02 | 35.6 | 5.5 | 0.22 | 32.0 | 74 |
| AGE07025_24M | B / S | 24 | 14.0~26.4 | 0.06 | 3600 | 1.02 | 35.6 | 5.5 | 0.22 | 32.0 | 74 |
| AGE07025_48M | B / S | 48 | 28.0~56.0 | 0.05 | 3600 | 1.02 | 35.6 | 5.5 | 0.22 | 32.0 | 74 |
| AGE07025_12H | B / S | 12 | 7.0~13.2 | 0.13 | 4000 | 1.13 | 39.9 | 6.8 | 0.27 | 37.0 | 74 |
| AGE07025_24H | B / S | 24 | 14.0~26.4 | 0.08 | 4000 | 1.13 | 39.9 | 6.8 | 0.27 | 37.0 | 74 |
| AGE07025_48H | B / S | 48 | 28.0~56.0 | 0.07 | 4000 | 1.13 | 39.9 | 6.8 | 0.27 | 37.0 | 74 |
| AGE07025_12U | B | 12 | 7.0~13.2 | 0.16 | 5500 | 1.55 | 54.8 | 12.8 | 0.50 | 45.0 | 74 |
| AGE07025_24U | B | 24 | 14.0~26.4 | 0.35 | 5500 | 1.55 | 54.8 | 12.8 | 0.50 | 45.0 | 74 |

*Bearing system B: Two Ball Bearing F: Fluid Bearing S: Sleeve Bearing

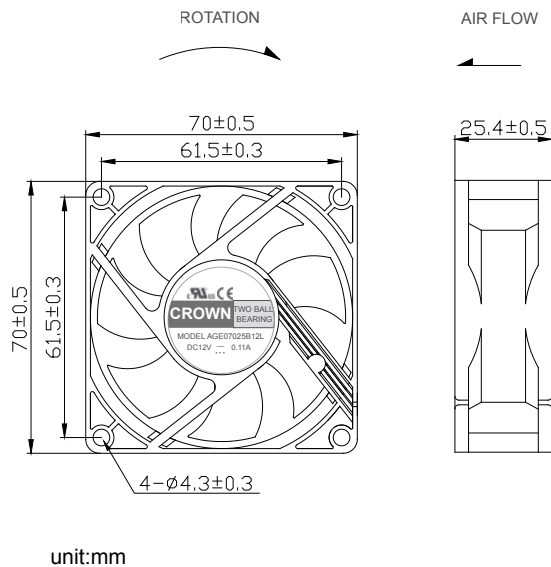
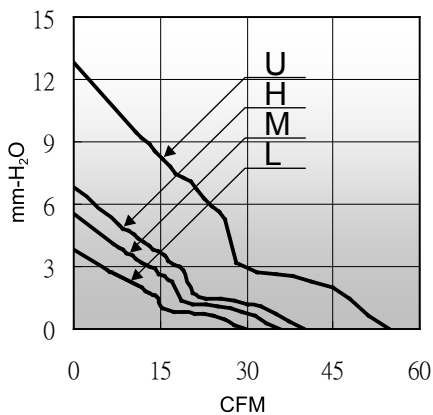

CROWN