

80 AG series

x80x15mm



General Specifications

- Motor : 4 Poles brushless DC motor
- Frame & Impeller : Plastic(UL 94V-0)
- Storage temperature : -40° to +75°
- Operating temperature : -10° to +70°

Major Characteristic Parameters

Model	*Bearing System	Rated Voltage	Operating Voltage Range	Rated Current	Rated Speed	Maximum Air Flow		Maximum Static Pressure		Sound Level	Weight
Part NO.	B / S / F	V	V	A	RPM	m ³ /min	CFM	mm-H ₂ O	In-H ₂ O	dBA	g
AGE08015_12J	B S	12	7.0~13.2	0.06	2400	0.65	23.1	1.5	0.06	28.0	54
AGE08015_24J	B S	24	14.0~26.4	0.04	2400	0.65	23.1	1.5	0.06	28.0	54
AGE08015_12L	B S	12	7.0~13.2	0.08	2700	0.82	28.9	2.4	0.09	31.0	54
AGE08015_24L	B S	24	14.0~26.4	0.06	2700	0.82	28.9	2.4	0.09	31.0	54
AGE08015_12M	B S	12	7.0~13.2	0.11	3100	0.94	33.1	2.9	0.12	34.0	54
AGE08015_24M	B S	24	14.0~26.4	0.08	3100	0.94	33.1	2.9	0.12	34.0	54
AGE08015_12H	B S	12	7.0~13.2	0.15	3600	1.12	39.6	4.2	0.16	39.0	54
AGE08015_24H	B S	24	14.0~26.4	0.09	3600	1.12	39.6	4.2	0.16	39.0	54
AGE08015_12U	B S	12	7.0~13.2	0.30	4500	1.35	47.6	5.5	0.22	43.0	54

*Bearing system B: Two Ball Bearing F: Fluid Bearing S: Sleeve Bearing

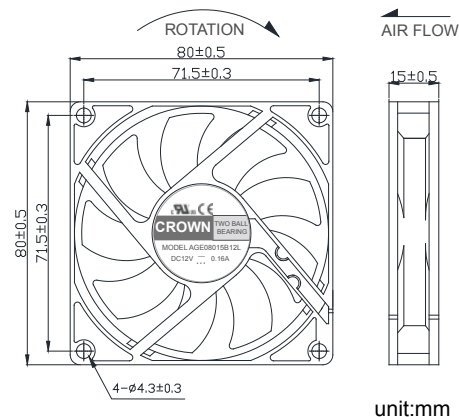
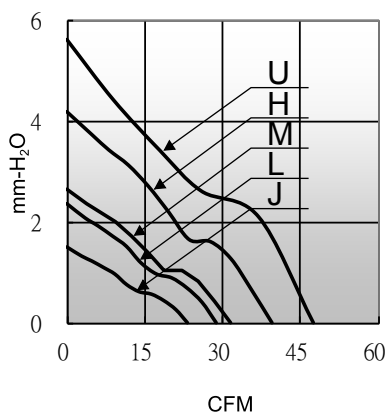

80 AG series

x80x15mm



General Specifications

- Motor : 4 Poles brushless DC motor
- Frame & Impeller : Plastic(UL 94V-0)
- Storage temperature : -40° to +75°
- Operating temperature : -10° to +70°

Major Characteristic Parameters

Model	*Bearing System	Rated Voltage	Operating Voltage Range	Rated Current	Rated Speed	Maximum Air Flow		Maximum Static Pressure		Sound Level	Weight
Part NO.	B / S / F	V	V	A	RPM	m ³ /min	CFM	mm-H ₂ O	In-H ₂ O	dBA	g
AGC08015_12J	B S	12	7.0~13.2	0.06	2400	0.65	23.1	1.5	0.06	28.0	54
AGC08015_24J	B S	24	14.0~26.4	0.04	2400	0.65	23.1	1.5	0.06	28.0	54
AGC08015_12L	B S	12	7.0~13.2	0.08	2700	0.82	28.9	2.4	0.09	31.0	54
AGC08015_24L	B S	24	14.0~26.4	0.06	2700	0.82	28.9	2.4	0.09	31.0	54
AGC08015_12M	B S	12	7.0~13.2	0.11	3100	0.94	33.1	2.9	0.12	34.0	54
AGC08015_24M	B S	24	14.0~26.4	0.08	3100	0.94	33.1	2.9	0.12	34.0	54
AGC08015_12H	B S	12	7.0~13.2	0.15	3600	1.12	39.6	4.2	0.16	39.0	54
AGC08015_24H	B S	24	14.0~26.4	0.09	3600	1.12	39.6	4.2	0.16	39.0	54
AGC08015_12U	B S	12	7.0~13.2	0.30	4500	1.35	47.6	5.5	0.22	43.0	54

*Bearing system B: Two Ball Bearing F: Fluid Bearing S: Sleeve Bearing

