

# GP

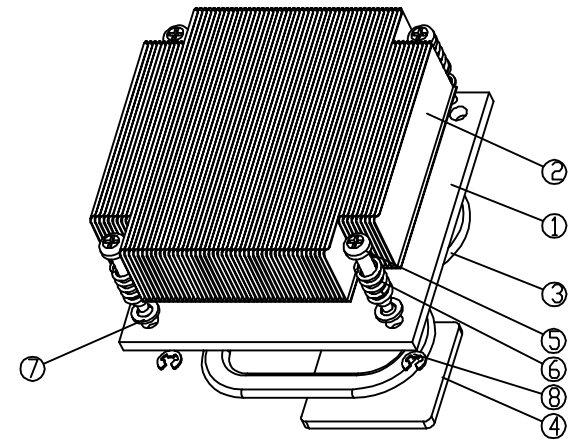
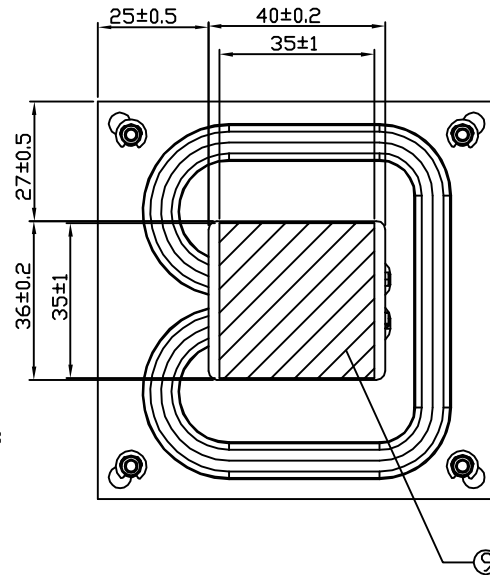
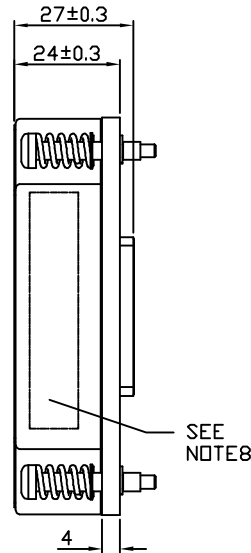
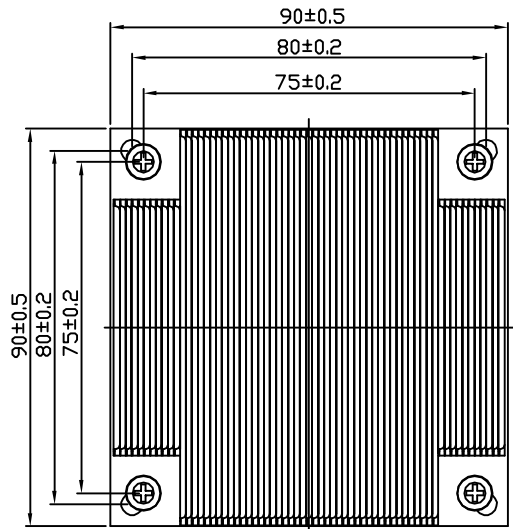

NOTE:  
 1. '(SPC)' DIMENSION NEED TO DO CPK CONTROL.  
 2. '\*dimension need to do critical control.  
 3. INTERPRET ALL DIMENSIONS AND TOLERANCES AS PER ASME Y14.5M 1994  
 4. REMOVE ALL SHARP EDGES AND BURRS  
 5. PART SHOULD BE FREE FROM OIL, DIRT AND OTHER CONTAMINANTS.  
 6. THE SINK BOTTOM FLATNESS SHALL BE 0.1 OR LESS  
 7. GREASE MATERIAL IS 7762 SIZE IS35X35X0.15  
 8. PRINT THE MANUFACTURED DATE: YY/MM/DD

ITEM	PART DESCRIPTION	Q'TY
1	HEAT SINK	1
2	FIN	1
3	PIPE	1
4	CU-BLOCK	1
5	SCREW	4
6	SPRING	4
7	WASHER	4
8	E-RING	4
9	GREASE(7762)	-G
-	SOLDER	-G
-	PACKAGE	-

DRN	Tony	12/07 2011	P/N:	JYCOL29ATPG-A
-----	------	---------------	------	---------------

REV	DESCRIPTION	DATE	MATERIAL:	FINISH:	REV:	CHK	Fanny	TITLE:	SCALE:
						APP	David	COOLER	---
REVISION HISTORY			CHIA CHERNE INDUSTRY CO., LTD. TEL: +886 4 7323090 FAX: +886 4 7383155				UNIT: M/M		